

DOCUMENT REPOSE - A RENDRE AVEC LA COPIE

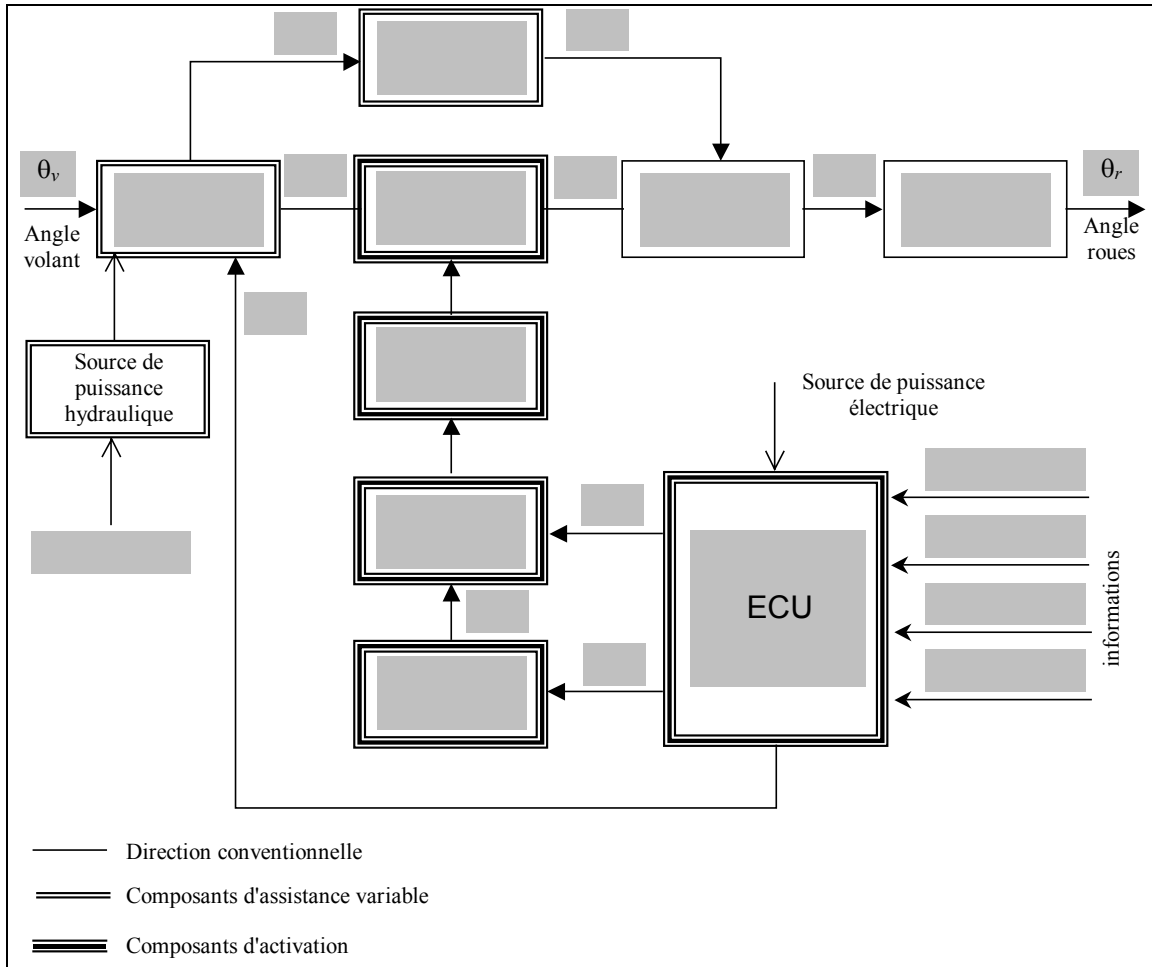

Figure R1. Architecture de la direction assistée active

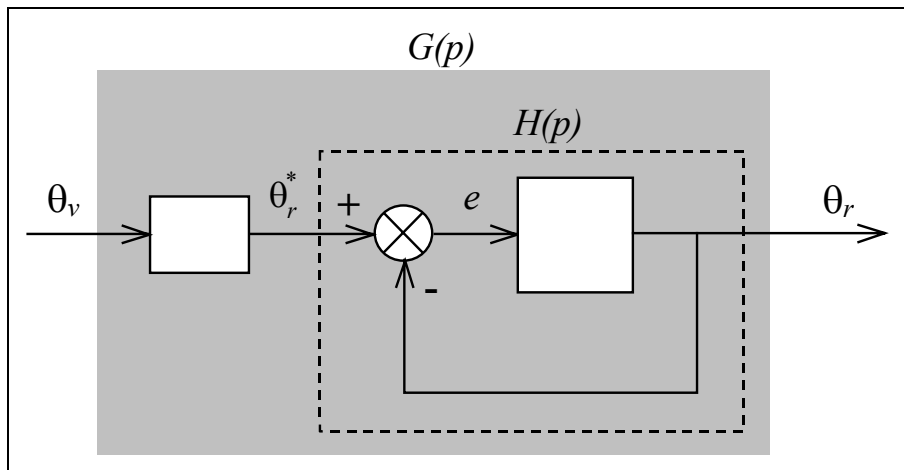

Figure R2. Schéma bloc de la fonction asservissement de position

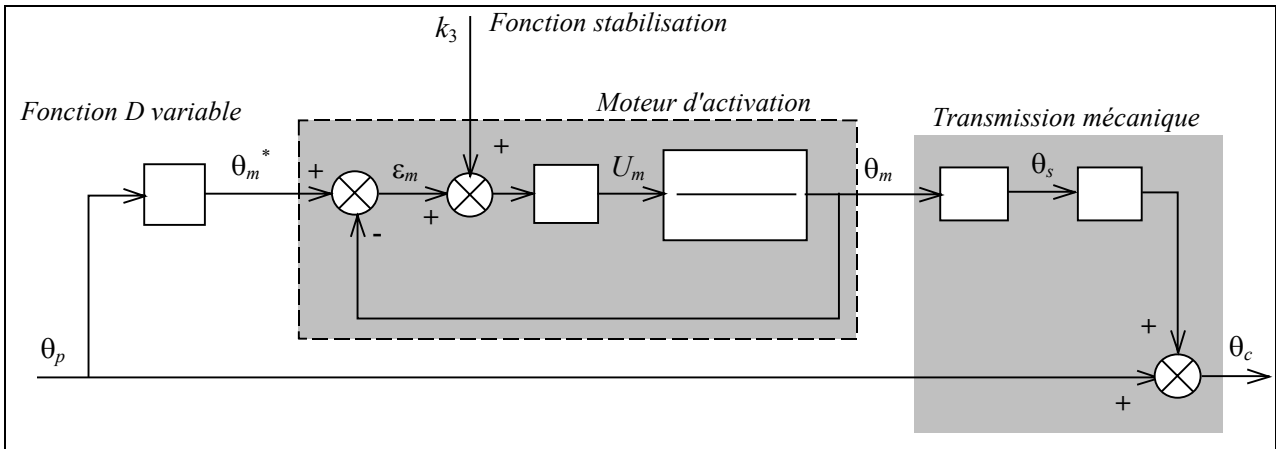

Figure R3. Schéma bloc du dispositif d'activation

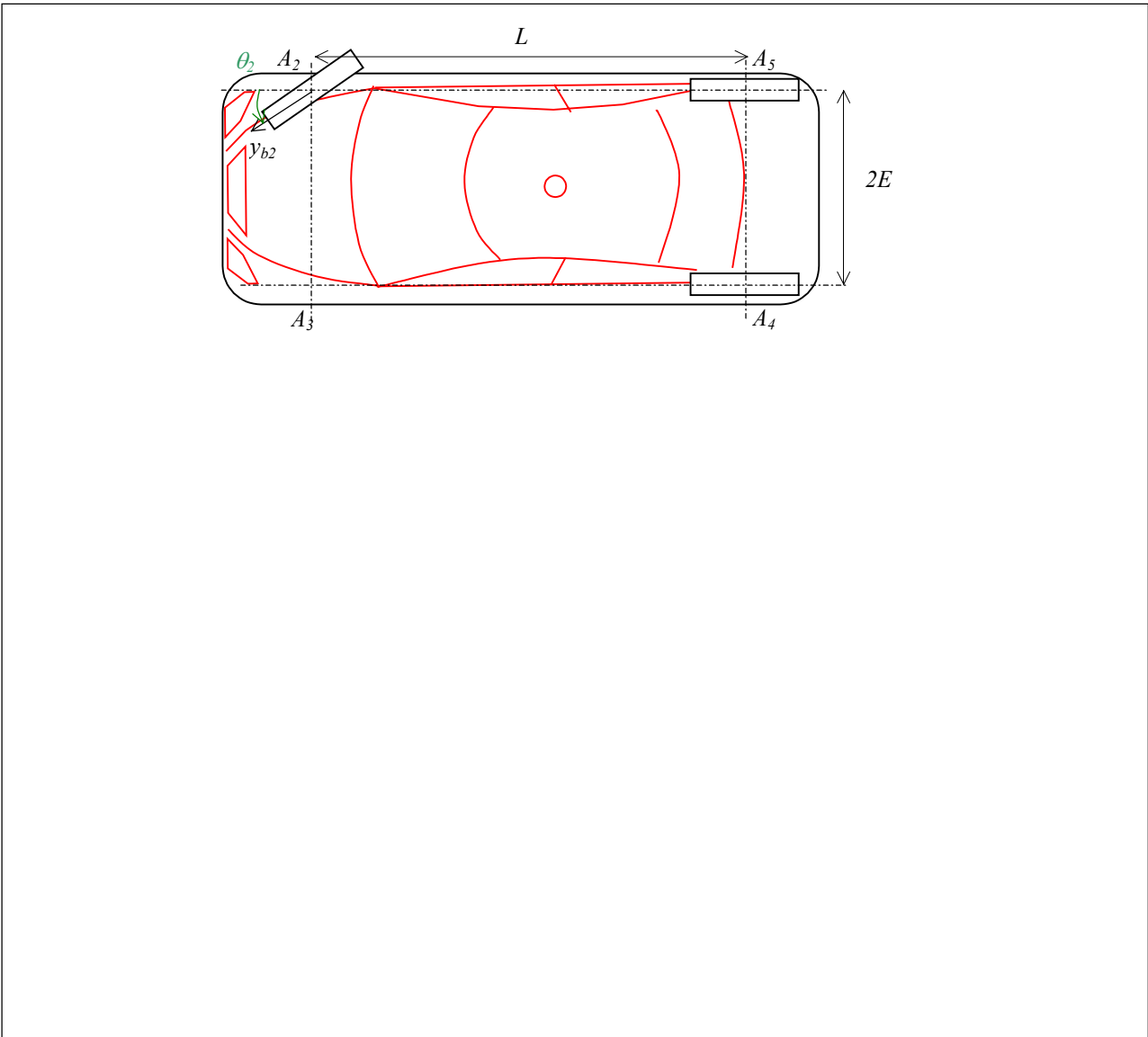

Figure R4. Détermination du CIR du véhicule